



# Flygt Flush Valve 4901, 4910

AUTOMATIC SUMP DESLUDGING

# Automatic and continuous sump desludging

**If grease and solids are permitted to build up in pump sumps, they can cause more than just an unpleasant smell. The pump's level regulators can become fouled, reducing operational efficiency and pump life. Flooding may occur. Regular desludging is therefore essential - and that means downtime and labor costs where mechanical desludging is used.**

Flygt's Flush Valve provides a simple, effective, and fully automatic way of continuously keeping pump sumps free of sludge by flushing the sump at the beginning of every pumping cycle. Sedimentation in the sump is greatly reduced, and unpleasant odors in and around the pumping station are virtually eliminated.

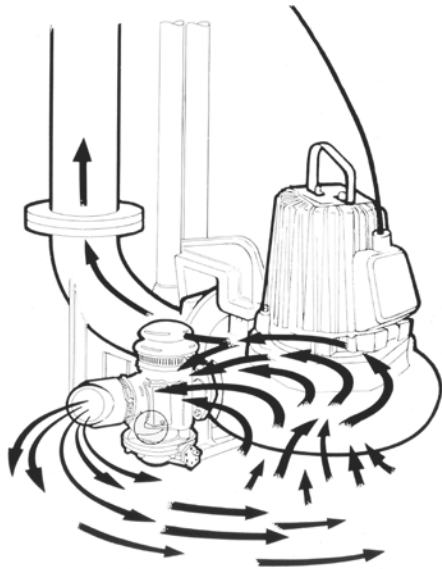

*When the pump starts, the valve opens for approximately 30 seconds, shooting out a powerful jet stream that flushes all solids into suspension, ready to be pumped away.*

*Because the flushing sequence is an integral part of the pumping cycle, flushing occurs every time the pump starts.*

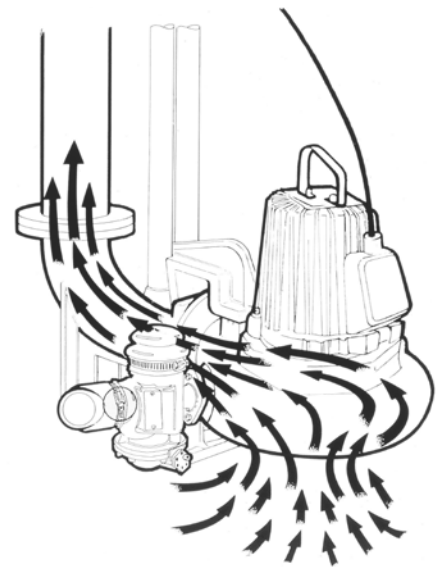

## How it works



*When the pump starts, the valve is open. The jet stream passing through the valve creates a negative pressure in the ball chamber relative to the pressure in an oil-filled chamber beneath the membrane.*

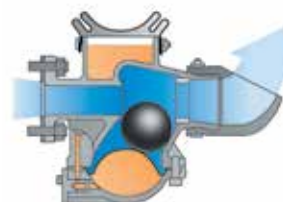

*During the next 20 seconds, the ball is lifted by the membrane as the pressure in the two chambers equalizes. The time this takes can be varied by regulating the oil flow from the oil reservoir to the chamber beneath the membrane.*

# Turns a pump into a powerful mixer

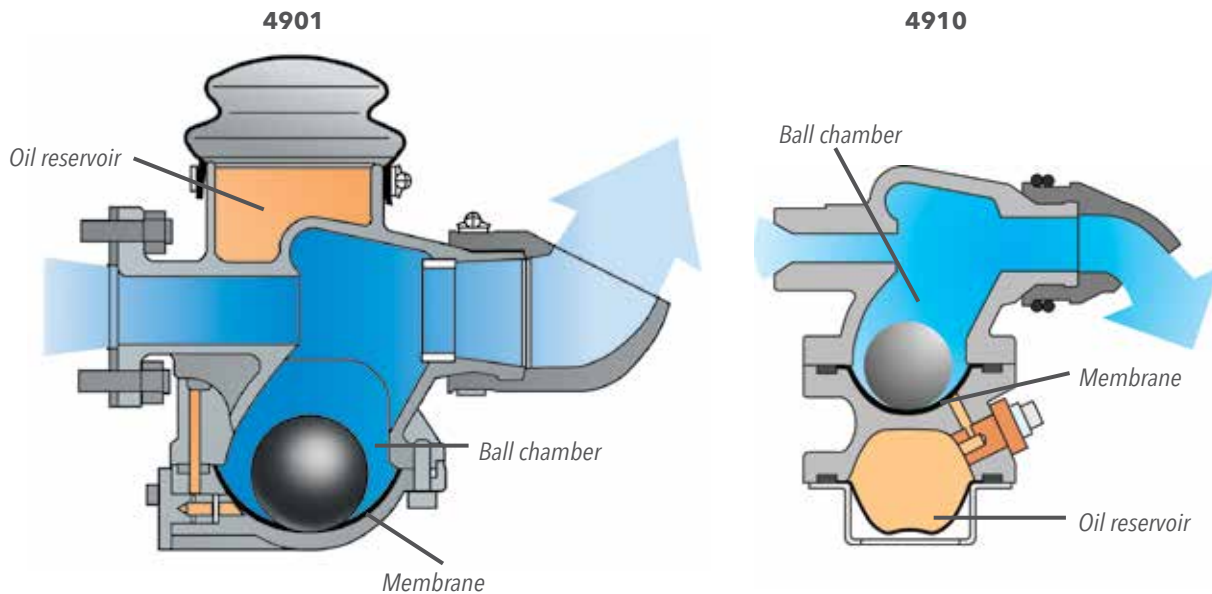

Fitting a Flush Valve harnesses the power of the pump to which it is fitted, creating an automatic flushing system that requires no additional power source. At the beginning of each pumping cycle, the valve is open, concentrating the power of the pump into a jet of water that flushes the sump. As a result, the contents of the sump are subjected to intense agitation, turning the pump momentarily into a powerful mixer. This re-suspends any sludge before the Flush Valve shuts off and the full power of the pump is again focused on pumping wastewater and the suspended solids out of the station. This unique system

also ensures a high degree of oxygenation, which helps to practically eliminate malodorous hydrogen sulphide.

The Flush Valve can be easily fitted to the volute of any CP, DP, or NP pump. Fitting just one Flush Valve in a wastewater pumping station less than 2.1 m in diameter eliminates the need for regular manual desludging. The result is significant savings in operation and maintenance costs, and much improved pumping efficiency.

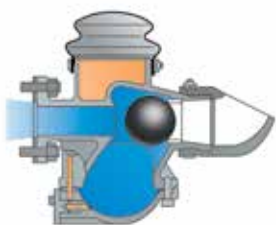

*The ball reaches a critical position and is forced by the jet stream into its seat, thus shutting off the valve. The power of the pump is now fully concentrated on draining the sump, and the pressure inside the valve presses the membrane back into its starting position.*



*When the pump stops, the pressure inside the valve is released and the ball falls back to its resting position. The valve is now open and ready for the next cycle.*

# Technical Data



<b>General:</b>	Flush Valve 4901 fits most pumps and can be retrofitted to all existing CP/NP 3085-3301 and DP 3085-3152 pumps.	Flush Valve 4910 fits all grinder pumps and can be retrofitted to all existing grinder pumps M 3068-3127.
<b>Length of flushing cycle:</b>	Recommended: 20 seconds Max. 50 seconds	Recommended: 20 seconds Max. 50 seconds
<b>Weight:</b>	17.64 lb	5.73 lb
<b>Ambient temperature:</b>	104 F° max	104 F° max
<b>Materials:</b>	Valve body: Cast iron Ball: Cast iron or polyurethane Membranes: Nitrile rubber Oil: Rapeseed oil	Valve body: Cast iron Ball: Ball bearing steel Membranes: Nitrile rubber Oil: Rapeseed oil

## Keep your station in top form

The Flush Valve is just one example of how Flygt can improve the cost-efficiency of a pumping station by keeping it cleaner and thus more reliable. Ask your Flygt representative for more information about the following.



Flygt is a brand of Xylem, whose 12,000 employees are addressing the most complex issues in the global water market.

[www.xyleminc.com](http://www.xyleminc.com)

Xylem, Inc.  
14125 South Bridge Circle  
Charlotte, NC 28273  
Tel 704.409.9700  
Fax 704.295.9080  
855-XYL-H201 (855-995-4261)